

FORMA DE SUMINISTRO: CADENA/STRIP

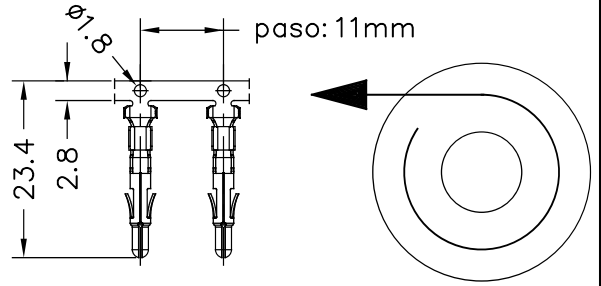

E: 1/1

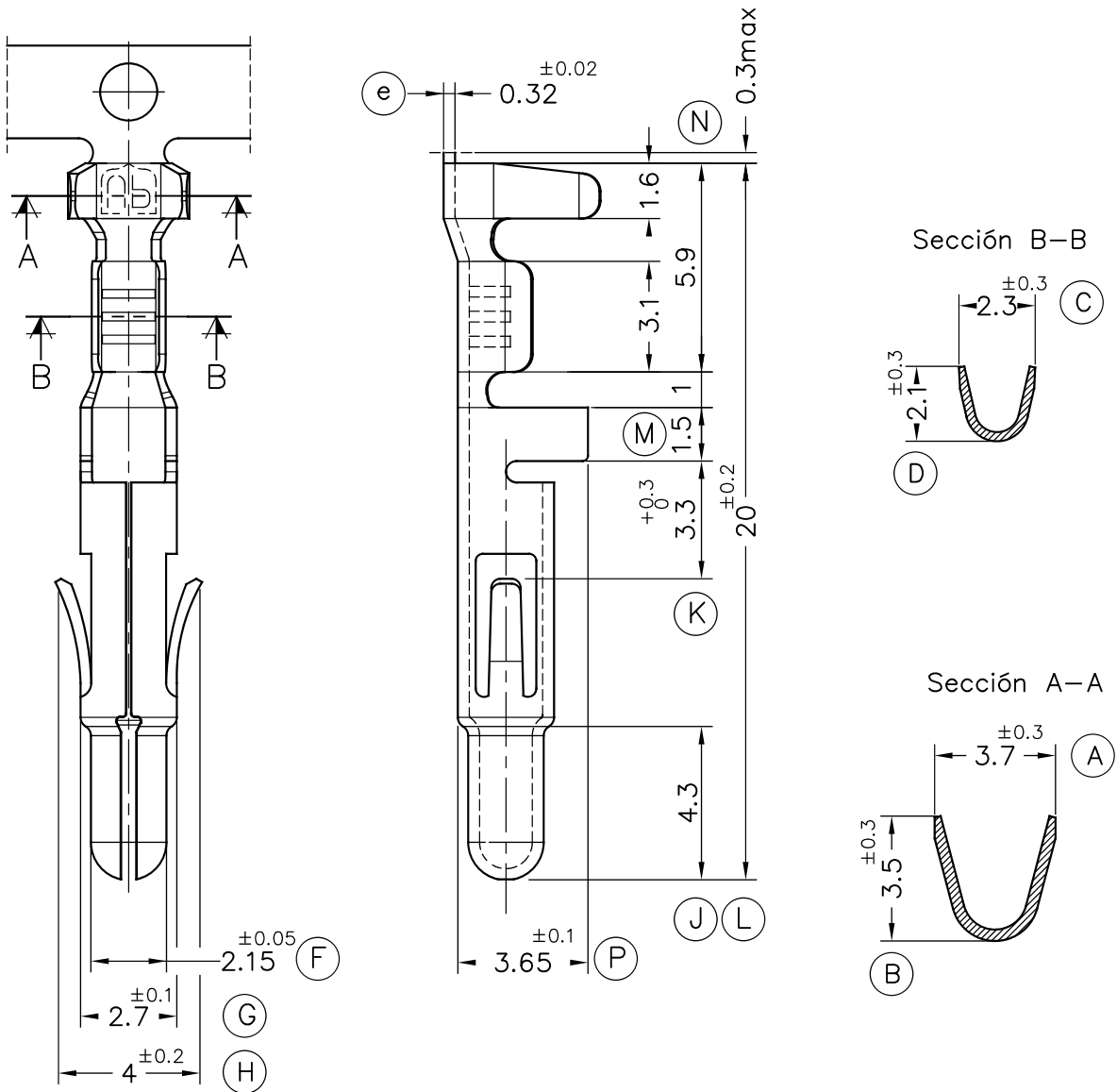

7525.01	PRE-Sn/TIN PLATED	CuZn30	0.25÷0.60mm ²	0.8÷2mm	01	Act. dim.	16/12/16
					00	1a. Edición	10/09/14
Referencias	Acabados/Finish	Material	Secc. Conductor	∅ Aislante	Rev.	Modificación	Fecha
ESCUBEDO Especialitats Elèctriques Escubedo S.A.		TERMINAL MACHO UP-LOCK2					
DIBUJADO	V.Roura	14/02/14			FORMATO	A4	
CONTROL	FAT	14/02/14	NORMAS MATERIALES	NORMAS DIMENSIONALES	TOLERANCIAS GENERALES	NOMBRE PT7525 "c"	
ESCALA	5/1		EN1654	Especiales	±0.2 ±2°	REF. 7525.XX	