

8845.**



SPECIAL TERMINALS - LAMP HOLDER 5W - SECONDARY LOCK

Description Lamp holder 5W – secondary lock

Wire section range 0.2 ÷ 0.6 mm² (AWG 24 ÷ 20)

Max. Insulator Ø 2.1 mm

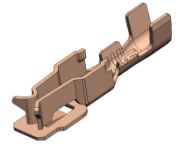

Materials, Temperature & Contact resistance

Part nr.	Material	Finish	Max. temp. (C°)	DV (mV)
8845.00	Brass	Natural	110	8.2
8845.01	Brass	Pre tin plated	120	6.5

Note: Voltage drop (crimp zone + contact zone) with lower section cable.

Material thickness 0.4 mm

Insertion/Withdrawal forces

1 st . Insertion	15 N Max.
1 st . Withdrawal	5 N Min.

Note: Measured value lamp-fitting (mounted with two terminations)

Application tool MN8816

Wire striping length 5.0 (±0.5) mm

Crimping parameters & Pull out force

Wire section (mm ² ±10%)		Conductor (mm)		Insulator (mm)	Pull-out force (N)
Nominal	Actual	Height (±0,05)	Width (measured)	Width (measured)	Escubedo
0.20	0.22	1.15	1.76	3.41	>40
0.35	0.34	1.20	1.77	3.41	>70
0.50	0.45	1.30	1.78	3.47	>110
0.60	0.55	1.35	1.78	3.48	>120

Note: Values only valid for the application tool specified. The insulator width is only indicative as they depend of the insulation properties.

Packaging 5000 Pieces on 25 mm cardboard reel, 11.5 mm terminal chain pitch

Drawing

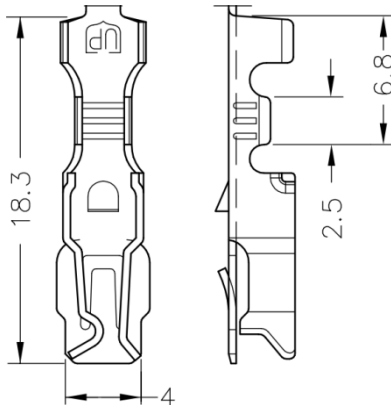

Approvals

- RoHS Compliant



Disclaimer

Data obtained from Escubedo Laboratory essays, using own methodology, cablings, equipment and original crimping tools, done in laboratory conditions and following the indicated standards, errors and omissions excepted. This document has no contractual meaning and it is published only for informative purposes. It can be changed without prior notice. The end customer has the sole responsibility to check these characteristics in its environment and with its own components, manufacturing methods and equipment. See also the full range product overview if available. For further information please visit our web site or contact us.

Rev. Nr.	Concept	Date	Created/Revised	Approved
2	Crimp data & sheet format update	26/11/2015	D.Martinez / E.Roura	JC Sanchez
1	Creation	03/05/2011	D.Martinez	A.Calvet