

4113E** 4.8 (.187) TYPE SERIES · RECEPTACLES FOR CONNECTOR



Specification	Low insertion
Typology	Without Upper Dimple
For male (mm)	4,8x0,5
Wire size mm² (AWG)	0,5-1,5 (20-16)
Ø Insulation (mm)	1,8-2,5

Materials, temperature and contact resistance

Part nr.	Material	Finishing	Max. Temp. (°C)
4113E00	Brass	Natural	110
4113E01	Brass	Pre-tin-plated	120
4113E24	Steel	Nickel-plated	300
4113E30	Bronze	Natural	120
4113E31	Bronze	Pre-tin-plated	130

Material thickness (mm) 0,35

Max. rated current

Wire section	4113E00 / 01 / 24 / 30 / 31
0.50 mm ²	8A
0.75 mm ²	10A
1.00 mm ²	12A
1.50 mm ²	16A

Insertion / Withdrawal forces

	4113E00 / 01 / 24 / 30 / 31
1st Insertion (max)	15N ¹
1st Withdrawal (max)	20N ¹
6th Withdrawal (min)	5N ¹

¹ Valid for Natural Brass Tab

Application tool MN4815E

Wire strip length 4.4 (±0.5) mm

Crimping parameters & pull out force

Wire section (±10%)	Conductor 		Insulator	Pull-out force (N)
	Height (mm)	Width (mm)		
0.50 mm ²	1.30 (±0.03)	2.36 (±0.03)	3.13 (±0.10)	56N @ 60s
0.75 mm ²	1.40 (±0.05)	2.37 (±0.05)	3.13 (±0.10)	84N @ 60s
1.00 mm ²	1.50 (±0.05)	2.39 (±0.05)	3.14 (±0.10)	108N @ 60s
1.50 mm ²	1.65 (±0.05)	2.40 (±0.05)	3.15 (±0.10)	150N @ 60s

Values only valid for the application tool specified upwards. The insulator widths are only indicative as they are dependent on the sheath thickness of the wire used.

Winding number 10000

Approvals



4113E**

4.8 (.187) TYPE SERIES · RECEPTACLES FOR CONNECTOR



Drawing

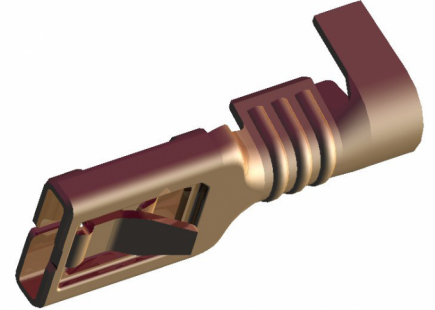
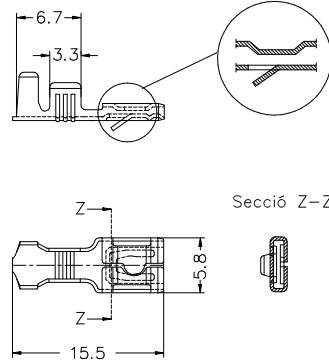

Disclaimer

Data obtained from Escubedo Laboratory essays, using own methodology, cablings, equipment and original crimping tools, done in laboratory conditions and following the indicated standards, errors and omissions excepted. This document has no contractual meaning and it is publiscised only for informative purposes. It can be changed without prior notice. The end customer has the sole responsibility to check these characteristics in its environment and with its own components, manufacturing methods and equipment. See also the full range product overview if available. For further information please visit our web site or contact us

Rev. Nr.	Concept	Date	Created/Revised	Approved
A2	Change company name and logo	2021-10-21	E.Roura (laboratory dept.)	M.Codina (engineering dept.)
A1	Datasheet generated automatically	2021-01-22	E.Roura (laboratory dept.)	M.Codina (engineering dept.)

Escubedo Connection Systems, S.A.U. · Ctra. de Girona-Olot Km. 35,5 · 17843 Riudellots de la Creu · Girona · Spain
Tel.: 34 972 171 706 · Fax: +34 972 171 714 · info@escubedo.com · www.escubedo.com