

Secc.X

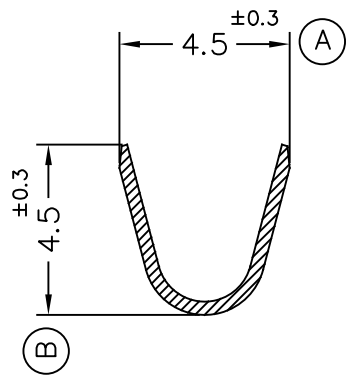

Secc.Y

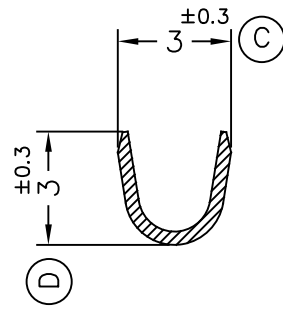

Secc.Z-Z

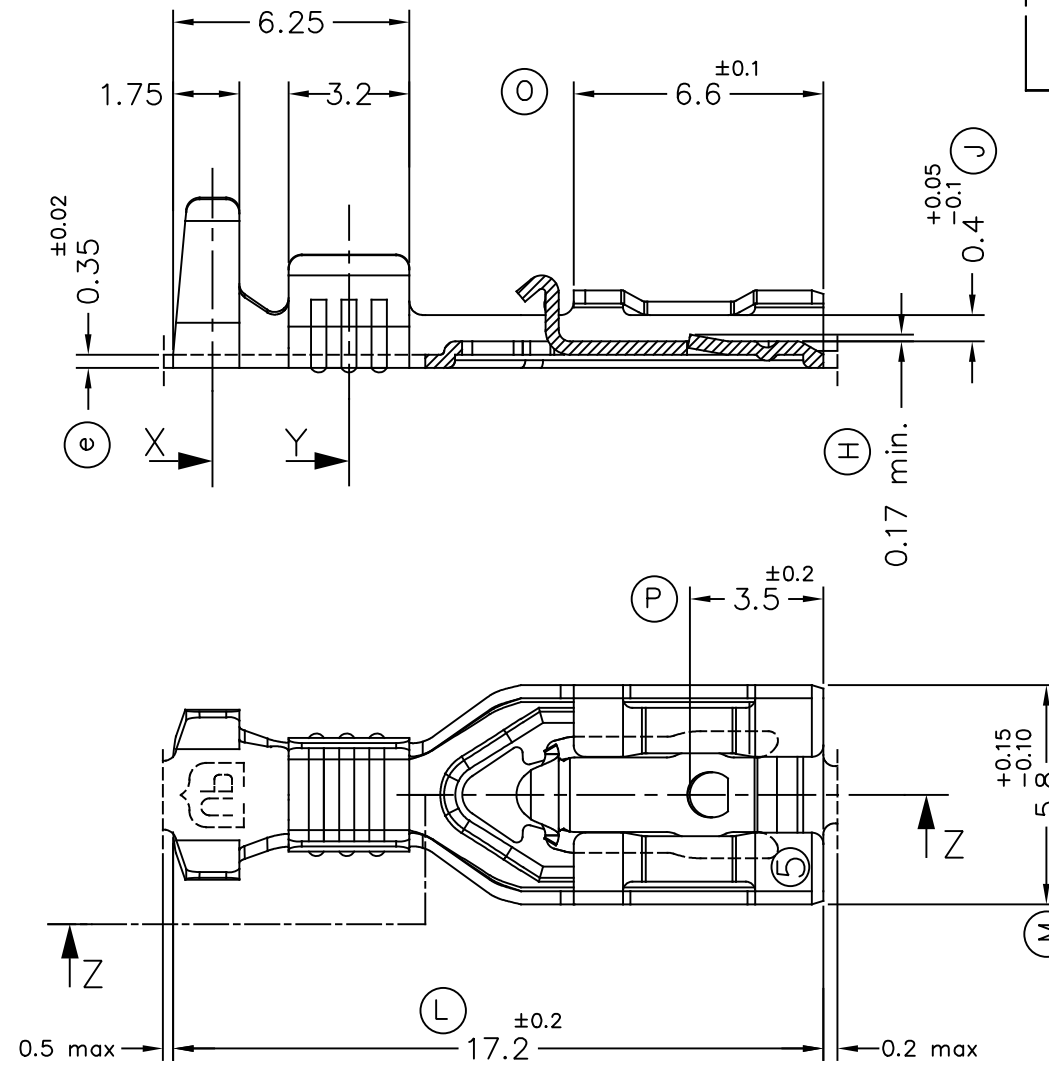

FORMA DE SUMINISTRO

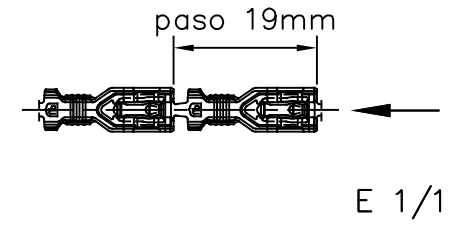

MACHO DE CONEXIÓN SUGERIDO/SUGGESTED MALE

- Material CuZn o Fe-Pre Ni
- Sin rebabas en el agujero/No burrs at hole
- Planitud dentro de 0.03mm en toda su longitud/ Flatness within 0.03mm over the whole length
- Agujero simétrico sobre el eje del macho/ Hole be symmetrical about tab acc. drawing specification

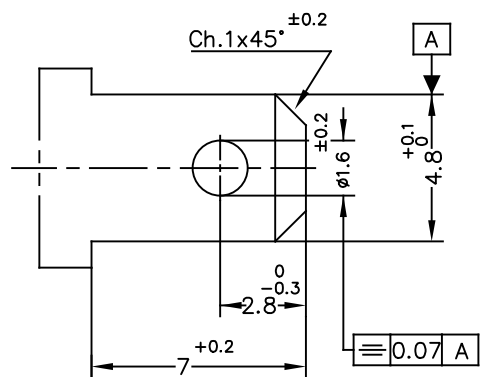
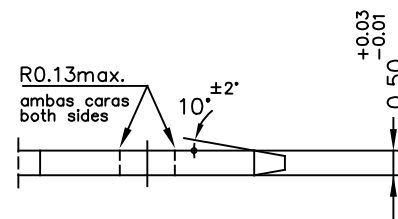

E 5:1

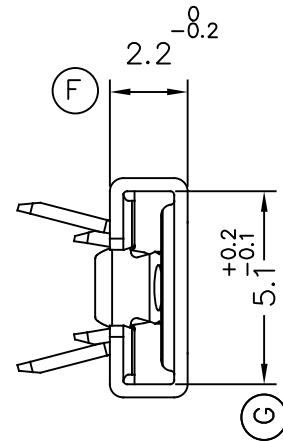

						04	O.Roura	Modificación cota H	26/07/21
4770.51	Pre-Sn	CuNiSi*	0.5 ÷ 1mm ²	1.8 ÷ 2.5mm.	4.8x0.5	03	D.Yabar	Corregir cota macho PTc	12/06/20
4770.24	Pre-Niq.	Acero				02		Mod. cota H y nota palanca	28/08/19
4770.01	Pre-Sn	Latón*				01 _{ve}		Tol.cota (H)/ (S)	01/06/16
4770.00	Natural	CuZn30				00		1ª Edición	21/01/16
Referencias	Acabados	Material	Sección Conductor	Ø Aislante	Para Macho	Rev.	Nombre	Modificación	Fecha



TERMINAL HEMBRA Serie 4.8
UP-TPSEK3



DIBUJADO	EP	21/01/16
CONTROL	XM	15/03/16
ESCALA	5/1	

NORMAS MATERIALES	NORMAS DIMENSIONALES	TOLERANCIAS GENERALES
EN 1654 *	Especiales	±0.2 ±2°

FORMATO	A3h
NOMBRE	PT4770 "c"
REF.	4770.xx