

5826.** 6.3 (.250) TYPE SERIES · FLAGS



Specification Long Flag

For male (mm) 6,3x0,8

Wire size mm² (AWG) 0,5-1 (20-18)

Ø Insulation (mm) 1,8-2,5

Materials, temperature and contact resistance

Part nr.	Material	Finishing	Max. Temp. (°C)	Contact Resist (mΩ)
5826.00	Brass	Natural	110	0.75
5826.01	Brass	Pre-tin-plated	120	0.50
5826.24	Steel	Nickel-plated	300	1.50
5826.51	Cu. Alloy	Pre-tin-plated	150	1.50

Material thickness (mm) 0,4

Max. rated current

Wire section	5826.00 / 01 / 24 / 51
0.50 mm ²	8A
0.75 mm ²	10A
1.00 mm ²	12A

Insertion / Withdrawal forces

	5826.00	5826.01 / 24 / 51
1st Insertion (max)	35N ¹	35N ¹
1st Withdrawal (max)	60N ¹	60N ¹
1st Withdrawal (min)	27N ¹	22N ¹
6th Withdrawal (min)	22N ¹	18N ¹

¹ Valid for Natural Brass Tab

Application tool MN5826

Wire strip length 5.5 (±0.5) mm

Crimping parameters & pull out force

Wire section (±10%)	Conductor 		Insulator	Pull-out force (N)
	Height (mm)	Width (mm)	Width (mm)	
0.50 mm ²	1.25 (±0.03)	2.42 (±0.03)	3.45 (±0.10)	56N @ 60s
0.75 mm ²	1.35 (±0.05)	2.43 (±0.05)	3.45 (±0.10)	84N @ 60s
1.00 mm ²	1.45 (±0.05)	2.44 (±0.05)	3.45 (±0.10)	108N @ 60s

Values only valid for the application tool specified upwards. The insulator widths are only indicative as they are dependent on the sheath thickness of the wire used.

Winding number 3300

Approvals



5826.** 6.3 (.250) TYPE SERIES · FLAGS



Drawing

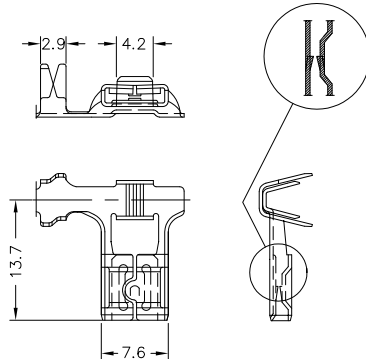

Disclaimer

Data obtained from Escubedo Laboratory essays, using own methodology, cablings, equipment and original crimping tools, done in laboratory conditions and following the indicated standards, errors and omissions excepted. This document has no contractual meaning and it is publicised only for informative purposes. It can be changed without prior notice. The end customer has the sole responsibility to check these characteristics in its environment and with its own components, manufacturing methods and equipment. See also the full range product overview if available. For further information please visit our web site or contact us

Rev. Nr.	Concept	Date	Created/Revised	Approved
A4	Update crimp specifications	2021-11-26	Laboratory Dept.	E. Roura (Laboratory Dept.)
A3	Update insertion and withdrawal forces	2021-11-12	E. Roura (Laboratory Dept.)	O. Roura (Engineering Dept.)
A2	Change company name and logo	2021-10-21	E. Roura (Laboratory Dept.)	O. Roura (Engineering Dept.)
A1	Datasheet generated automatically [A1]	2021-08-05	E. Roura (Laboratory Dept.)	O. Roura (Engineering Dept.)

Escubedo Connection Systems, S.A.U. · Ctra. de Girona-Olot Km. 35,5 · 17843 Riudellots de la Creu · Girona · Spain
Tel.: 34 972 171 706 · Fax: +34 972 171 714 · info@escubedo.com · www.escubedo.com